

4

3

2

1

REVISIONS - 0 BALLOONS DENOTE CHANGES			
REV.	DESCRIPTION	DATE	APPROVED
		04/04/2024	ZAG

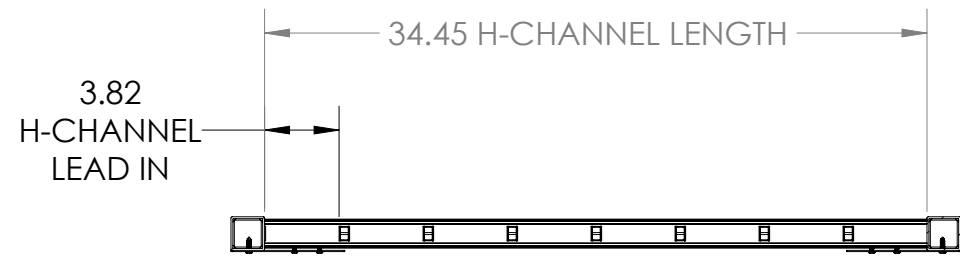

SECTION A-A

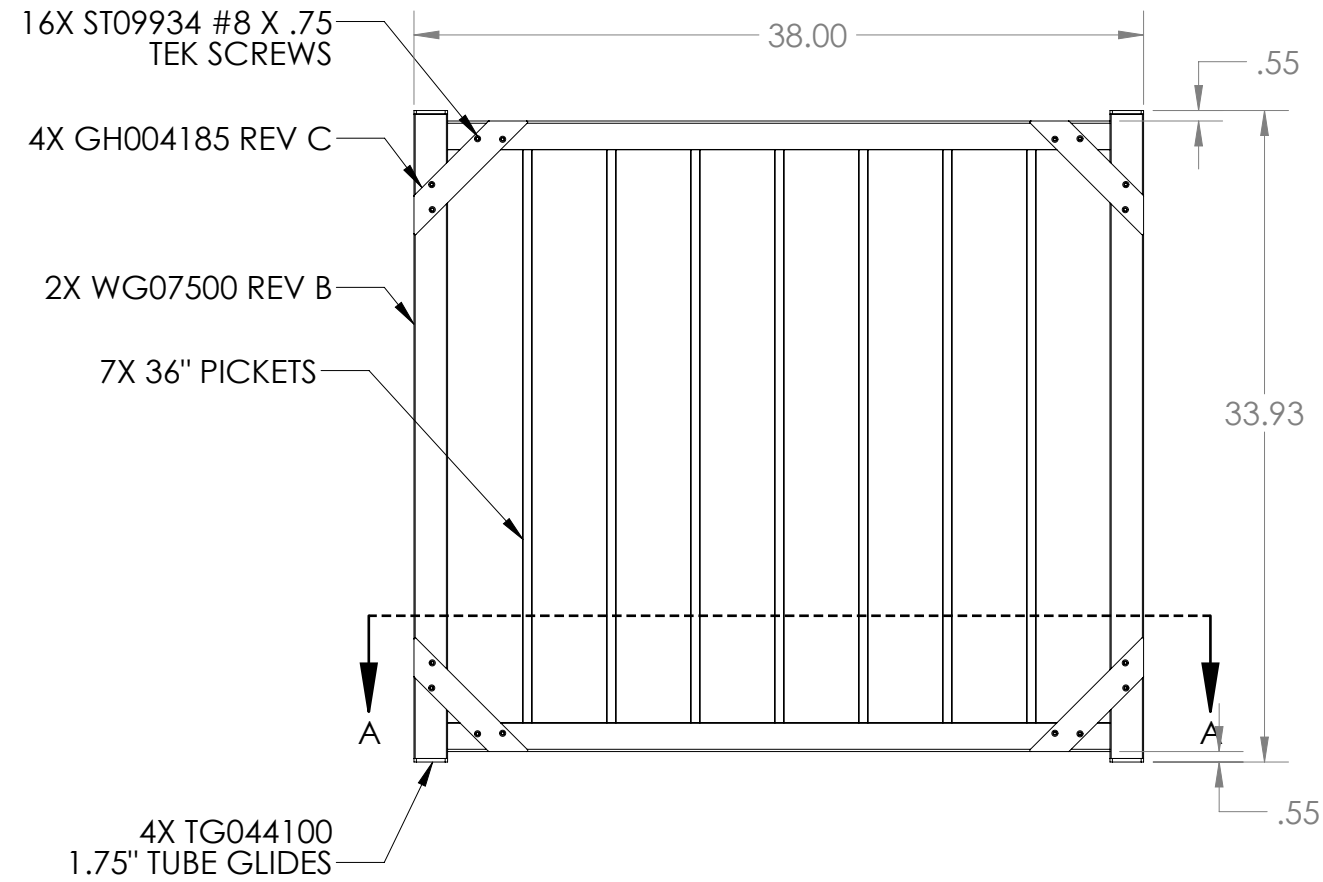
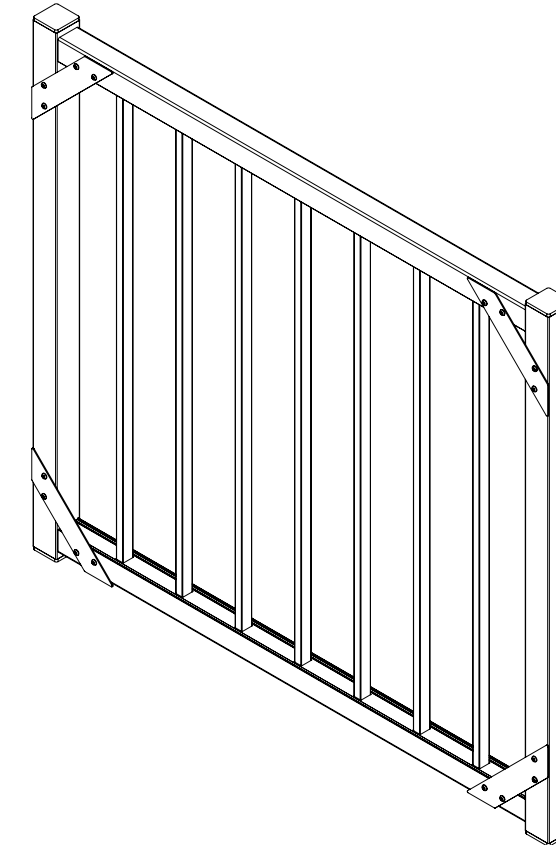

UNLESS OTHERWISE SPECIFIED:		NAME	DATE	
DIMENSIONS ARE IN INCHES		DRAWN	VINH 04/04/24	
TOLERANCES:		CHECKED		
SURFACE FINISH: 125 RMS		ENG APPR.		
ANGULAR: ±.5 DEG		MFG APPR.		TITLE: SHOP DRAWING, WILLIAMS GATE, 36" X 38" (FOR 39" OPENING)
LINEAR: .X ±.02				SIZE DWG. NO. REV
.XX ±.010				B WG07514 B
.XXX ±.005				SCALE: 1:6 WEIGHT: SHEET 1 OF 1
THIRD ANGLE PROJECTION:		INTERPRET GEOMETRIC TOLERANCING PER: ASME Y14.5-2009		
MATERIAL		PROPRIETARY AND CONFIDENTIAL THE INFORMATION CONTAINED IN THIS DRAWING IS THE SOLE PROPERTY OF UltraLox. ANY REPRODUCTION IN PART OR AS A WHOLE WITHOUT THE WRITTEN PERMISSION OF UltraLox.		
FINISH				
DO NOT SCALE DRAWING				

4

3

2

1